

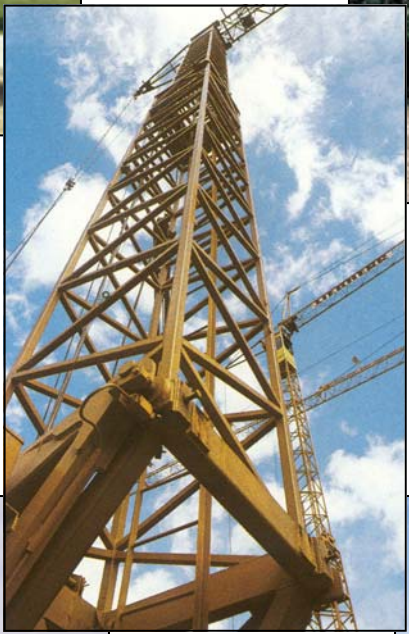

3610 Cedardale Road
Suite D
Mount Vernon, WA 98274



The Crane Specialists



Rental | Sales
Toll Free: 866-708-5001
Phone: 360-848-8491
Fax: 360-424-8566

Parts | Service
Toll Free: 866-508-2001
Phone: 253-572-2915
Fax: 253-572-2915



Locations:
Mount Vernon, WA / Tacoma, WA / Vancouver, WA
Atlanta, GA

Rental | Sales
Toll Free: 866-708-5001
Phone: 360-848-8491
Fax: 360-424-8566

Authorized Distributor for:



Parts | Service
Toll Free: 866-508-2001
Phone: 253-572-2914
Fax: 253-572-2915

GROVE®

RT9130E

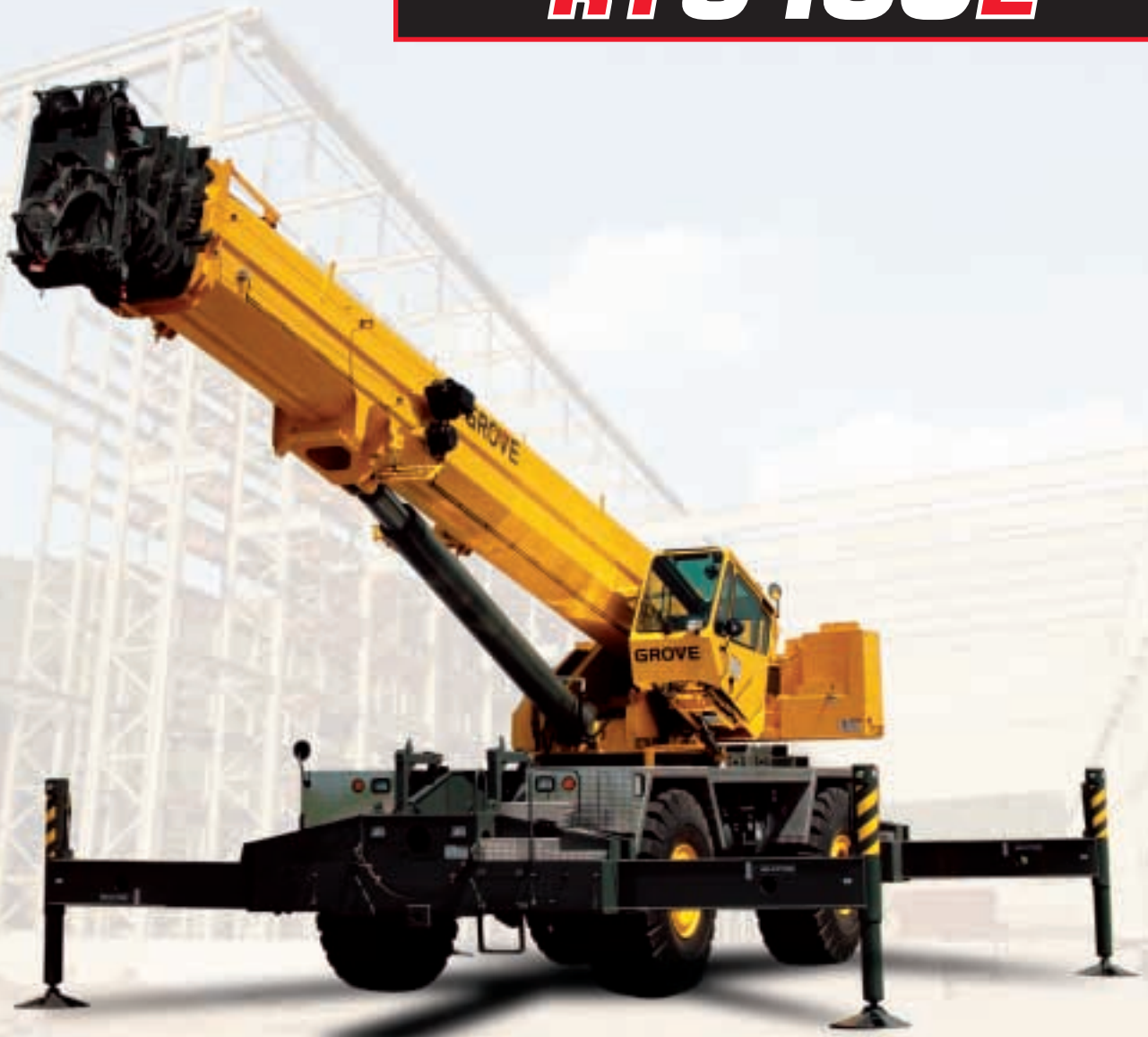

**ROUGH TERRAIN
HYDRAULIC CRANE**



Dimensions

TIRE SIZE	A	B	C	D	E	F	G	A	B	C	D	E	F	G
33.25X 29	718.00	742.00	620.00	586.00	569.00	461.00	403.00	524.00	544.00	404.00	370.00	353.00	244.00	220.00
	2 WHEEL STEER							4 WHEEL STEER						

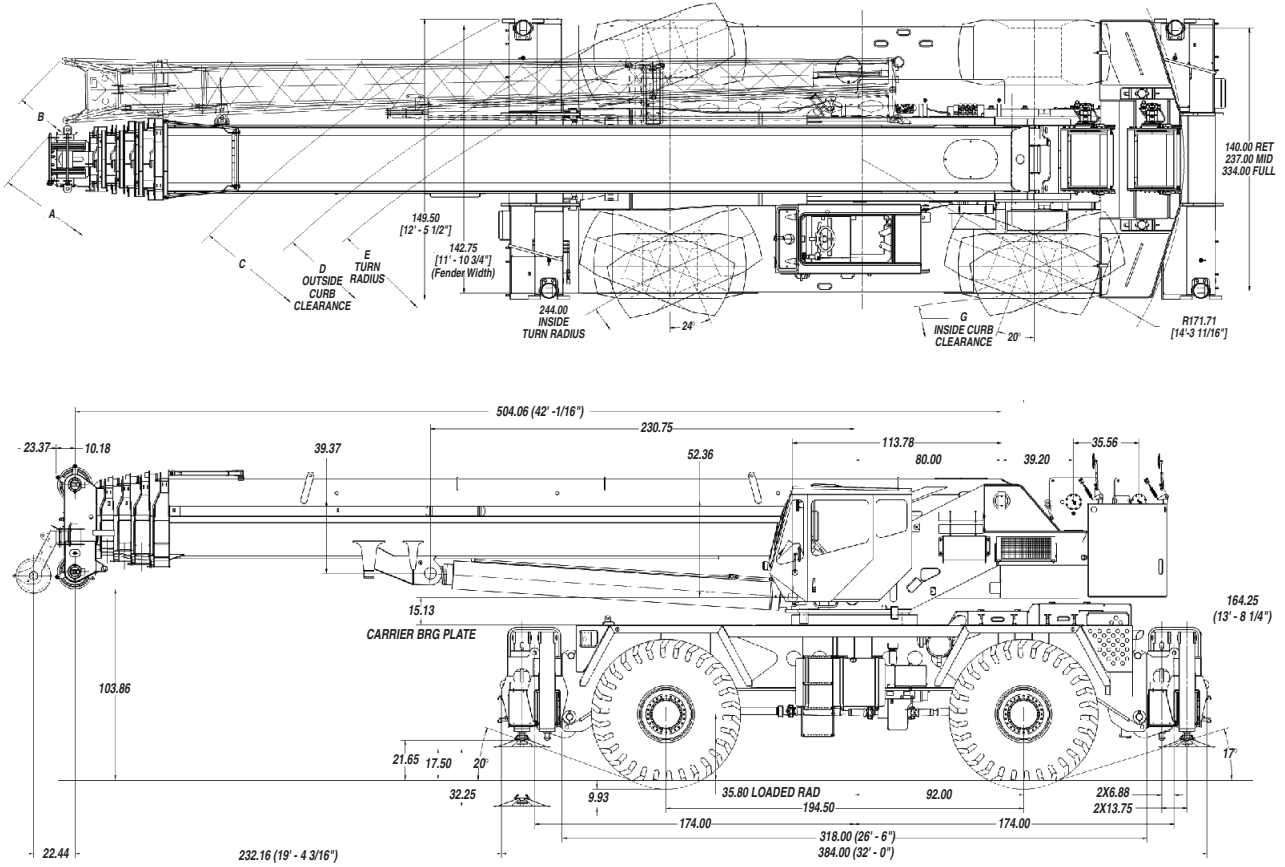

RT9130E Weight Configurations

Configuration	RT9130E Largest Load (Lbs.)	Items Removed (Lbs.)							Weight of Items Removed (Lbs.)	
		Boxes	STD Cwt	OPT Cwt	Aux Hoist	Boom	Bi-fold	Block &/or ball		33.25 Tires
Complete Machine: 2 Hoists w/Rope,MAX Counterweight, Bi-fold Extension,Block, Ball, 33.25x 25 Tires	174,285									
Remove 40K Cwt, Aux Hoist w/Mt & Rope	130,201		24,000	16,000	4,084					44,084
Remove 40K Cwt, Aux Hoist w/Mt & Rope, Tires	120,681		24,000	16,000	4,084				9,520	53,604
Remove 40K Cwt, Aux Hoist w/Mt & Rope, Bi-fold, Tires	117,571		24,000	16,000	4,084		3,110		9,520	56,714
Remove 40K Cwt, Aux Hoist w/Mt & Rope, O/R Boxes	111,455	18,746	24,000	16,000	4,084					62,830
Remove 40K Cwt, Aux Hoist w/Mt & Rope, Bi-fold, Block, O/R Boxes	106,745	18,746	24,000	16,000	4,084		3,110	1,600		67,540
Remove Boom,Bi-fold, Block, Ball, 40K Cwt, Aux Hoist w/Mt & Rope	91,291		24,000	16,000	4,084	33,500	3,110	2,300		82,994
Remove Boom,Bi-fold, Block, Ball, 40K Cwt, Aux Hoist w/Mt & Rope,Tires	81,771		24,000	16,000	4,084	33,500	3,110	2,300	9,520	92,514
Remove Boom,Bi-fold, Block, Ball, 40K Cwt, Aux Hoist w/Mt & Rope,O/R Boxes	72,545	18,746	24,000	16,000	4,084	33,500	3,110	2,300		101,740

Working Range



42-160 ft.
(12.8-48.8 m)



36-59 ft.
(11-18 m)

Bi-fold Swingaway

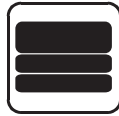

40,000 lbs.
(18 144 kg)

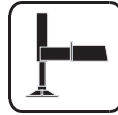

100%



360°

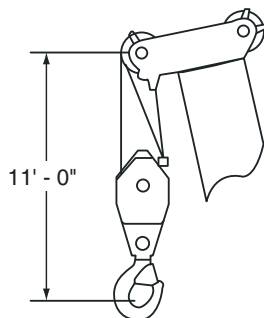
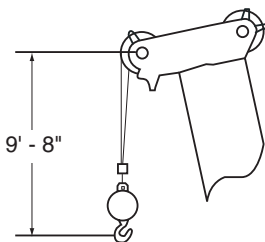
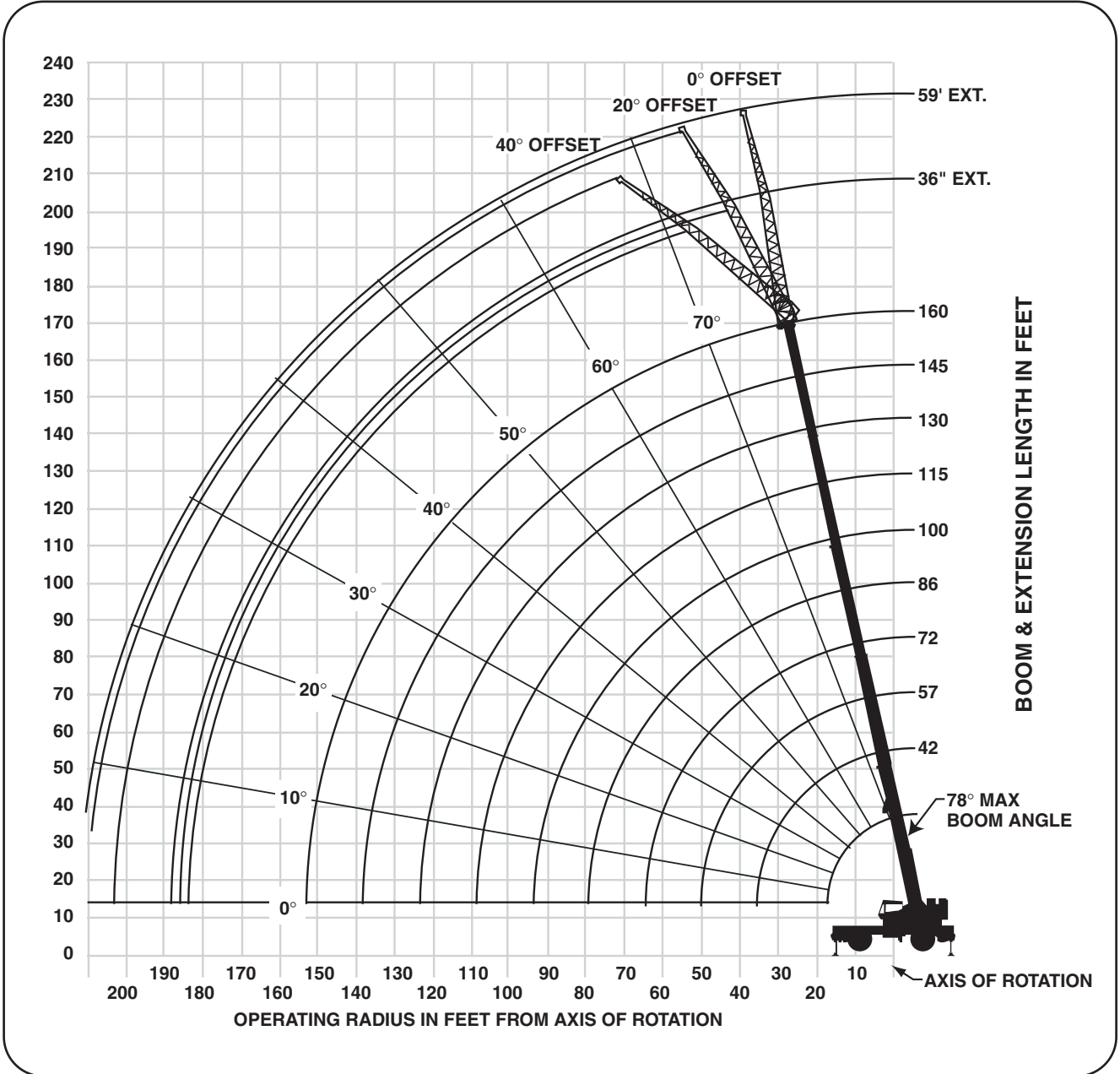

Dimensions are for largest Grove furnished hookblock and headache ball, with anti-two block activated.

Superstructure Specifications

Boom

42 ft. - 160 ft. (12.8 m - 48.8 m) five-section, sequenced synchronized full power boom. Maximum tip height: 169 ft. (51.5 m)

Lattice Extension

36 ft. - 59 ft. (11 m - 18 m) offsettable bifold lattice swingaway extension. Offsets 0°, 20° and 40°. Stows alongside base boom section. Maximum tip height: 227 ft. (69.2 m)

*Optional Lattice Extension

36 ft. - 59 ft. (11 m - 18 m) **hydraulically** offsettable bifold lattice swingaway extension. Offsets from 0° to 40°. Stows alongside base boom section. Maximum tip height: 227 ft. (69.2 m)

*Optional Lattice Extension Inserts

(2) x 26 ft (8 m) lattice extension inserts. Installs between the boom nose and bifold extension, nonstowable. Maximum tip height: 279 ft. (85 m)

Boom Nose

Seven nylatron sheaves mounted on heavy duty tapered roller bearings with removable pin-type rope guards. Quick reeving type boom nose. Removable auxiliary boom nose with removable pin type rope guard.

Boom Elevation

One double acting hydraulic cylinder with integral holding valve provides elevation from -3° to 78°.

Load Moment & Anti-Two Block System

Standard "Graphic Display" load moment and anti-two block system with audio-visual warning and control lever lockout. These systems provide electronic display of boom angle, length, radius, tip height, relative load moment, maximum permissible load, load indication and warning of impending two-block condition. The standard Work Area Definition System allows the operator to pre-select and define safe working areas. If the crane approaches the pre-set limits, audio-visual warnings aid the operator in avoiding job-site obstructions.

Cab

20° tilt, full-vision, all-steel fabricated with acoustical lining and tinted safety glass throughout. Deluxe seat incorporates armrest-mounted hydraulic single-axis controllers. Dash panel incorporates gauges for all engine functions. Other standard features include: hot water heater, cab circulating air fan, sliding side and rear windows, sliding skylight with electric wiper and sunscreen, electric windshield wash/wipe, fire extinguisher and seat belt.

Swing

Two speed, (2) planetary swing drives with foot applied multi-disc wet brakes. Spring applied, hydraulically released swing brakes. 360° positive swing lock and 2 position mechanical house lock, both operated from cab. Maximum speed: 2.5 RPM

Counterweight

40,000 lb. (18 144 kg) of total counterweight. Hydraulically installed and removed.

Hydraulic System

Six main pumps with a combined capacity of 205 GPM (776 LPM). Maximum operating pressure: 4800 psi (331 bar). Two individual post pressure compensated valve banks. Return line type filter with full flow by-pass protection and service indicator. Replaceable cartridge with micron filtration rating of 5/12/16. 325 gallons (1230 L) reservoir. Remote mounted oil cooler with thermostatically controlled hydraulic driven motor, fan/air to oil. System pressure ports.

Hoist Specifications

Main and Auxiliary Hoist

Planetary reduction with automatic spring applied multi-disc brake. Electronic hoist drum rotation indicator, and hoist drum cable followers.

Maximum Single Line Pull: 1st layer - 19,834 lb. (8 997 kg)
3rd layer - 16,866 lb. (7 650 kg)
5th layer - 14,671 lb. (6 655 kg)

Maximum Permissible Line Pull:
16,800 lb. (7 620 kg) with 6x37 class rope
12,920 lb. (5 860 kg) with 18x19 class rope

Maximum Single Line Speed: 562 FPM (171 m/min)

Rope Class:
6x37 EIPS IWRC, Special Flexible
18x19 EIPS WSC, Rotation Resistant

Rope Diameter: 3/4" (19 mm)

Rope Length:
Main Hoist - 950 ft. (290 m)
Auxiliary Hoist - 700 ft. (213 m)

Maximum Rope Stowage: 1,206 ft. (368 m)

Carrier Specifications

Chassis

Box section frame fabricated from high-strength, low alloy steel. Removable outrigger housings, front/rear towing and tie down lugs.

Outrigger System

Four hydraulic telescoping single-stage double box beam outriggers with inverted jacks and integral holding valves. Three positions setting, 0%, 50% and fully extended. Outrigger boxes removable for ease of transportation. All steel fabricated, quick release type outrigger floats, 30.5" (775 mm) diameter. Maximum outrigger pad load - 166,000 lb.

Outrigger Controls

Controls and crane level indicator located in cab.

Engine

Cummins QSC8.3L diesel, six cylinders, 300 bhp (224 kW) (Gross) @ 2,200 RPM
Maximum torque: 1000 ft. lb. (1356 Nm) @ 1,300 RPM

Fuel Tank Capacity

100 gallons (379 L)

Transmission

Full powershift with 6 forward and 3 reverse speeds. Front axle disconnect for 4 x 2 travel.

Electrical System

Two 12 V - maintenance free batteries.
12 V starting and lighting.

Drive

4 x 4

Steering

Fully independent power steering:
Front: Full hydraulic steering wheel controlled.
Rear: Full hydraulic switch controlled.
Provides infinite variations of 4 main steering modes: front only, rear only, crab and coordinated.
Rear steer indicator.

Axles

Front: Drive/steer with differential and planetary reduction hubs rigid mounted to frame.
Rear: Drive/steer with differential and planetary reduction hubs pivot mounted to frame.

Oscillation Lockouts

Automatic full hydraulic lockouts on rear axle permits 10 in. (254 mm) oscillation with boom centered over the front.

Brakes

Full hydraulic split circuit, dry disc service brakes operating on all wheels. Spring-applied, hydraulically released parking brake mounted on front axle.

Tires

Std. 33.25 x 29 - 38 bias ply, General SL-100
*Optional: 29.5R29 radial, Michelin XRB

Lights

Full lighting including turn indicators, head, tail, brake and hazard warning lights.

Maximum Speed

15 MPH (24 kph)

Gradeability (Theoretical)

73% (Based on 180,000 lb. [81 647 kg] GVW) 33.25 x 29 tires, pumps engaged, 160 ft. (48.8 m) boom, plus 59 ft. (18 m) swingaway, 40,000 lb. (18 144 kg) counterweight, hookblock and headache ball.

Miscellaneous Standard Equipment

Full width aluminum fenders, full length aluminum decking, dual rear view mirrors, hook-block tie down, electronic back-up alarm, light package, front stowage well, tachometer/hourmeter, immersion type block heater, rear wheel position indicator, 36,000 Btu hot water cab heater, hoist mirrors, engine distress A/V warning system, front/rear tie down and tow lugs, coolant sight level indicator, hydraulic pump disconnect, LMI light bar. Hydraulically activated boom removal pins, lift cylinder travel support, 80T hookblock, 10T top swivel ball.

OPTIONAL EQUIPMENT

- *AUXILIARY LIGHTING PACKAGE (includes cab mounted amber flashing light, cab mounted 360° rotation spotlight and dual base boom mounted floodlights)
- *Air conditioning
- *130 ton hookblock
- *Rear pintle hook
- *Cab controlled cross axle differential locks, (front and rear)
- *PAT datalogger
- *Rubber mat for stowage trough
- *Tire removal tool

**Denotes optional equipment*

**RATED LIFTING CAPACITIES IN POUNDS WITH 40,000 LB. COUNTERWEIGHT
42 FT. - 160 FT. BOOM**

ON OUTRIGGERS FULLY EXTENDED - 360°

Radius in Feet	#0001								
	Main Boom Length in Feet								
	42	57	72	86	100	115	130	145	160
10	+260,000 (71.5)	147,000 (76.5)							
12	224,000 (68.5)	147,000 (74.5)	*127,000 (78)						
15	176,000 (63.5)	147,000 (71.5)	127,000 (76)	*92,600 (78)					
20	127,500 (55.5)	125,500 (65.5)	115,500 (71.5)	86,550 (75.5)	*65,000 (78)				
25	97,300 (46)	95,550 (60)	95,300 (67)	78,900 (72)	62,650 (75)	44,600 (78)			
30	76,900 (34)	75,250 (53.5)	75,050 (62.5)	68,500 (68.5)	56,800 (72)	44,600 (75.5)	43,150 (78)		
35		60,950 (46.5)	60,750 (58)	60,100 (64.5)	50,050 (69)	44,600 (73)	42,200 (76)	32,550 (78)	
40		50,300 (38.5)	50,150 (52.5)	50,550 (60.5)	44,050 (66)	41,400 (70)	38,000 (73.5)	32,550 (76)	25,100 (78)
45		42,050 (28)	41,950 (47)	42,350 (56.5)	38,950 (62.5)	37,450 (67.5)	34,150 (71)	32,550 (74)	24,800 (76.5)
50			35,400 (41)	35,850 (52.5)	34,650 (59)	33,450 (64.5)	31,350 (68.5)	29,550 (71.5)	24,500 (74.5)
55	See Note 16		30,050 (34)	30,550 (47.5)	30,050 (55.5)	30,000 (61.5)	29,200 (66)	26,850 (69.5)	24,000 (72.5)
60			25,600 (24.5)	26,100 (42.5)	25,850 (52)	26,950 (58.5)	26,350 (63.5)	24,700 (67.5)	23,200 (70.5)
65				22,400 (37)	22,150 (48)	23,800 (55.5)	23,850 (61)	22,950 (65)	21,100 (68.5)
70				19,200 (30.5)	18,950 (44)	20,800 (52.5)	21,600 (58.5)	20,850 (62.5)	19,200 (66.5)
75				16,400 (22)	16,200 (39)	18,100 (49)	19,250 (55.5)	19,000 (60.5)	17,500 (64.5)
80					13,800 (34)	15,700 (45.5)	16,900 (52.5)	17,100 (58)	15,750 (62.5)
85					11,650 (28)	13,550 (41.5)	15,000 (49.5)	15,500 (55.5)	14,300 (60)
90					9,770 (19.5)	11,700 (37)	13,100 (46.5)	13,900 (53)	13,100 (58)
95						10,000 (32)	11,450 (43)	12,250 (50)	12,150 (55.5)
100						8,490 (26.5)	9,940 (39.5)	11,000 (47)	11,400 (53)
105						5,690 (18.5)	8,630 (35.5)	9,730 (44)	10,200 (50.5)
110							7,320 (30.5)	8,460 (41)	9,020 (48)
115							6,220 (25)	7,370 (37.5)	8,100 (45.5)
120							5,120 (17.5)	6,280 (33.5)	7,190 (42.5)
125								5,350 (29.5)	6,270 (39.5)
130								4,430 (24)	5,350 (36)
135								2,560 (16.5)	4,560 (32.5)
140									3,770 (28)
Minimum boom angle (deg.) for indicated length (no load)									23
Maximum boom length (ft.) at 0 deg. boom angle (no load)									145

#LMI operating code. Refer to LMI manual for instructions.

*This capacity is based upon maximum obtainable boom angle.

+16 parts line and 6x37 rope required to lift this capacity (using aux. boom nose). Refer to Operator's and Safety Handbook for reeving diagram.

Note: () Boom angles are in degrees.

Lifting Capacities at Zero Degree Boom Angle									
Boom Angle	Main Boom Length in Feet								
	42	57	72	86	100	115	130	145	160
0°	41,400 (35.3)	24,650 (50)	15,350 (64.6)	9,700 (79.3)	5,250 (94)	3,650 (108.6)	2,450 (123.3)	1,450 (138)	

Note: () Reference radii in feet.

A6-829-101977A

THIS CHART IS ONLY A GUIDE AND SHOULD NOT BE USED TO OPERATE THE CRANE. The individual crane's load chart, operating instructions and other instructional plates must be read and understood prior to operating the crane.

36 FT. - 59 FT. FOLDING BOOM EXTENSION WITH 40,000 LB. COUNTERWEIGHT & 100 FT. MAIN BOOM ON OUTRIGGERS FULLY EXTENDED - 360°

Radius in Feet	36 ft. LENGTH			59 ft. LENGTH		
	0° OFFSET	20° OFFSET	40° OFFSET	0° OFFSET	20° OFFSET	40° OFFSET
	#0021	#0022	#0023	#0041	#0042	#0043
25	*33,600 (78)					
30	33,600 (76.5)			*14,950 (78)		
35	32,950 (74.5)	*23,150 (78)		14,950 (77.5)		
40	31,050 (72)	22,150 (76.5)		14,950 (76)		
45	29,250 (70)	21,250 (74)	17,250 (78)	14,950 (74)		
50	27,600 (67.5)	20,450 (72)	16,850 (75.5)	14,950 (72)	12,350 (78)	
55	26,150 (65)	19,700 (69.5)	16,500 (73)	14,950 (70)	11,900 (77)	
60	24,750 (63)	19,050 (67)	16,150 (70.5)	14,800 (68)	11,500 (75)	
65	23,550 (60.5)	18,450 (65)	15,900 (68)	14,300 (66)	11,100 (73)	9,210 (78)
70	22,050 (58)	17,850 (62)	15,650 (65.5)	13,650 (64)	10,700 (71)	9,000 (76)
75	20,100 (55.5)	17,350 (59.5)	15,450 (63)	13,100 (62)	10,400 (69)	8,820 (73.5)
80	18,100 (52.5)	16,900 (57)	15,250 (60)	12,550 (60)	10,050 (66.5)	8,650 (71.5)
85	16,000 (50)	16,500 (54)	15,150 (57)	12,000 (58)	9,780 (64.5)	8,490 (69)
90	14,150 (47)	15,500 (51.5)	15,050 (54)	11,550 (55.5)	9,510 (62.5)	8,360 (66.5)
95	12,500 (44)	13,700 (48)	14,000 (50.5)	11,100 (53)	9,260 (60)	8,240 (64)
100	11,050 (40.5)	12,100 (45)	12,750 (47)	10,650 (51)	9,030 (57.5)	8,130 (61.5)
105	9,770 (37)	10,650 (41.5)		10,250 (48.5)	8,820 (55)	8,050 (59)
110	8,490 (33.5)	9,270 (37.5)		9,930 (46)	8,620 (52.5)	7,980 (56)
115	7,430 (29)	8,060 (33)		9,040 (43)	8,450 (49.5)	7,950 (53)
120	6,370 (24)	6,850 (28)		8,150 (40.5)	8,280 (47)	7,920 (50)
125				7,240 (37)	7,830 (43.5)	7,900 (46.5)
130				6,340 (34)	7,380 (40.5)	7,890 (42.5)
135				5,570 (30.5)	6,440 (36.5)	
140				4,800 (26)	5,510 (32)	
145				4,140 (21)		
150				3,480 (14)		
Min. boom angle for indicated length (no load)	0°	20°	40°	0°	20°	40°
Max. boom length at 0° boom angle (no load)	100 ft.			100 ft.		

NOTE: () Boom angles are in degrees.

A6-829-102109

#LMI operating code. Refer to LMI manual for operating instructions.

*This capacity is based on maximum obtainable boom angle.

NOTES:

1. All capacities above the bold line are based on structural strength of boom extension.
2. 36 ft. boom extension may be used for single or double line lifting service. 59 ft. boom extension may be used for single line lifting service only.

WARNING: Lifting with the 36 ft. extension base, with the 23 ft. extension fly either erected or folded along side of extension base, is strictly prohibited.

3. Radii listed are for a fully extended boom with the boom extension erected. For main boom lengths less than fully extended, the rated loads are determined by boom angle. Use only the column which corresponds to the boom extension length and offset for which the machine is configured. For boom angles not shown, use the rating of the next lower boom angle.

WARNING: Operation of this machine with heavier loads than the capacities listed is strictly prohibited. Machine tipping with boom extension occurs rapidly and without advance warning.

4. Boom angle is the angle above or below horizontal of the longitudinal axis of the boom base section after lifting rated load.
5. Capacities listed are with outriggers properly extended and vertical jacks set only.

THIS CHART IS ONLY A GUIDE AND SHOULD NOT BE USED TO OPERATE THE CRANE. The individual crane's load chart, operating instructions and other instructional plates must be read and understood prior to operating the crane.

36 FT. - 59 FT. FOLDING BOOM EXTENSION WITH 40,000 LB. COUNTERWEIGHT & 130 FT. MAIN BOOM ON OUTRIGGERS FULLY EXTENDED - 360°

Radius in Feet	36 ft. LENGTH			59 ft. LENGTH		
	0° OFFSET	20° OFFSET	40° OFFSET	0° OFFSET	20° OFFSET	40° OFFSET
	#0021	#0022	#0023	#0041	#0042	#0043
35	23,350 (78)					
40	23,350 (77)			12,300 (78)		
45	23,350 (75)	*21,300 (78)		12,300 (77.5)		
50	23,350 (73.5)	20,700 (76.5)		12,300 (76)		
55	23,350 (71.5)	20,100 (75)	16,600 (78)	12,300 (74.5)		
60	23,350 (69.5)	19,500 (73)	16,350 (76)	12,300 (73)	11,600 (78)	
65	22,300 (67.5)	19,000 (71)	16,100 (74)	12,300 (71.5)	11,300 (77)	
70	20,350 (66)	18,500 (69)	15,850 (72)	12,300 (69.5)	10,950 (75)	
75	18,350 (64)	18,050 (67)	15,650 (70)	12,300 (68)	10,700 (73.5)	8,940 (78)
80	16,600 (62)	17,100 (65)	15,500 (68)	12,300 (66.5)	10,400 (72)	8,790 (76)
85	15,050 (60)	15,550 (63)	15,300 (66)	12,300 (64.5)	10,150 (70)	8,650 (74.5)
90	13,700 (57.5)	14,150 (61)	14,500 (63.5)	12,300 (63)	9,910 (68.5)	8,520 (72.5)
95	12,450 (55.5)	12,900 (58.5)	13,250 (61.5)	11,900 (61)	9,680 (66.5)	8,410 (70.5)
100	11,300 (53.5)	11,750 (56.5)	12,100 (59)	11,450 (59)	9,460 (64.5)	8,300 (68.5)
105	10,300 (51)	10,750 (54)	11,050 (56.5)	10,500 (57.5)	9,260 (63)	8,210 (66.5)
110	9,390 (48.5)	9,810 (52)	10,050 (54)	9,580 (55.5)	9,060 (61)	8,120 (64.5)
115	8,570 (46)	8,970 (49.5)	9,200 (51.5)	8,790 (53.5)	8,860 (59)	8,050 (62.5)
120	7,750 (43.5)	8,140 (46.5)	8,350 (48.5)	8,010 (51.5)	8,660 (57)	7,990 (60.5)
125	6,840 (41)	7,360 (44)	7,600 (45.5)	7,340 (49.5)	7,960 (54.5)	7,820 (58)
130	5,940 (38)	6,590 (41)	6,850 (42.5)	6,680 (47.5)	7,270 (52.5)	7,660 (55.5)
135	5,170 (34.5)	5,730 (37.5)		6,100 (45)	6,660 (50.5)	7,010 (53.5)
140	4,400 (31)	4,880 (34)		5,530 (42.5)	6,050 (48)	6,360 (50.5)
145	3,730 (27.5)	4,120 (30)		4,890 (40)	5,510 (45.5)	5,770 (48)
150	3,070 (22.5)	3,360 (25.5)		4,260 (37.5)	4,970 (42.5)	5,190 (45)
155				3,670 (35)	4,360 (40)	
160				3,090 (31.5)	3,750 (36.5)	
165				2,570 (28.5)	3,120 (33)	
170				2,060 (24.5)	2,490 (29)	
Min. boom angle for indicated length (no load)	20°	20°	40°	20°	20°	40°
Max. boom length at 0° boom angle (no load)	100 ft.			100 ft.		

NOTE: () Boom angles are in degrees.

A6-829-102127

#LMI operating code. Refer to LMI manual for operating instructions.

*This capacity is based on maximum obtainable boom angle.

NOTES:

1. All capacities above the bold line are based on structural strength of boom extension.
2. 36 ft. boom extension may be used for single or double line lifting service. 59 ft. boom extension may be used for single line lifting service only.

WARNING: Lifting with the 36 ft. extension base, with the 23 ft. extension fly either erected or folded along side of extension base, is strictly prohibited.

3. Radii listed are for a fully extended boom with the boom extension erected. For main boom lengths less than fully extended, the rated loads are determined by boom angle. Use only the column which corresponds to the boom extension length and offset for which the machine is configured. For boom angles not shown, use the rating of the next lower boom angle.

WARNING: Operation of this machine with heavier loads than the capacities listed is strictly prohibited. Machine tipping with boom extension occurs rapidly and without advance warning.

4. Boom angle is the angle above or below horizontal of the longitudinal axis of the boom base section after lifting rated load.
5. Capacities listed are with outriggers properly extended and vertical jacks set only.

**36 FT. - 59 FT. FOLDING BOOM EXTENSION
WITH 40,000 LB. COUNTERWEIGHT & 160 FT. MAIN BOOM
ON OUTRIGGERS FULLY EXTENDED - 360°**

Radius in Feet	36 ft. LENGTH			59 ft. LENGTH		
	0° OFFSET	20° OFFSET	40° OFFSET	0° OFFSET	20° OFFSET	40° OFFSET
	#0021	#0022	#0023	#0041	#0042	#0043
45	16,000 (78)					
50	16,000 (77.5)					
55	15,900 (76)			10,100 (78)		
60	15,850 (74)	15,700 (77.5)		10,100 (77)		
65	15,800 (72.5)	15,700 (76)	*15,200 (78)	10,100 (75.5)		
70	15,750 (71)	15,000 (74.5)	14,750 (77)	10,100 (74)	10,050 (78)	
75	14,950 (69.5)	14,300 (73)	14,100 (75.5)	10,100 (73)	10,050 (77.5)	
80	14,200 (68)	13,600 (71)	13,450 (74)	10,100 (71.5)	10,050 (76)	
85	13,450 (66)	12,950 (69.5)	12,850 (72)	10,100 (70)	10,050 (74.5)	8,600 (78)
90	12,800 (64.5)	12,350 (68)	12,250 (70.5)	10,100 (68.5)	9,870 (73)	8,500 (77.5)
95	11,700 (63)	11,750 (66)	11,700 (68.5)	10,100 (67)	9,680 (72)	8,400 (75.5)
100	10,650 (61)	11,200 (64.5)	11,200 (67)	9,710 (65.5)	9,450 (70)	8,310 (74)
105	9,710 (59.5)	10,250 (62.5)	10,400 (65)	9,280 (64)	9,050 (68.5)	8,220 (72.5)
110	8,780 (57.5)	9,310 (61)	9,680 (63)	8,850 (62.5)	8,650 (67)	8,140 (71)
115	7,990 (55.5)	8,500 (59)	8,840 (61)	8,110 (61)	8,280 (65.5)	7,920 (69.5)
120	7,210 (53.5)	7,690 (57)	8,010 (59)	7,370 (59.5)	7,920 (64)	7,700 (67.5)
125	6,540 (52)	7,000 (55)	7,290 (57)	6,720 (57.5)	7,360 (62.5)	7,440 (66)
130	5,880 (49.5)	6,310 (53)	6,580 (55)	6,070 (56)	6,810 (60.5)	7,190 (64)
135	5,300 (47.5)	5,710 (51)	5,950 (53)	5,510 (54.5)	6,210 (59)	6,630 (62.5)
140	4,730 (45.5)	5,110 (49)	5,330 (50.5)	4,950 (52.5)	5,620 (57)	6,080 (60.5)
145	4,190 (43)	4,580 (46.5)	4,770 (48)	4,460 (50.5)	5,100 (55.5)	5,520 (58.5)
150	3,650 (41)	4,060 (44)	4,220 (45.5)	3,980 (49)	4,580 (53.5)	4,970 (56.5)
155	3,070 (38.5)	3,500 (41.5)	3,660 (43)	3,550 (47)	4,120 (51.5)	4,470 (54.5)
160	2,490 (35.5)	2,940 (38.5)		3,130 (45)	3,660 (49.5)	3,970 (52)
165	1,970 (32.5)	2,370 (36)		2,710 (43)	3,240 (47.5)	3,510 (50)
170	1,460 (29.5)	1,800 (32.5)		2,300 (40.5)	2,830 (45)	3,060 (47.5)
175				1,840 (38.5)	2,420 (43)	2,640 (45)
180				1,390 (36)	2,010 (40)	2,220 (42)
185					1,530 (37.5)	
Min. boom angle (°) for indicated length (no load)	26	28	40	34	35	40
Max. boom length (ft.) at 0° boom angle (no load)	100			100		

NOTE: () Boom angles are in degrees.

A6-829-101980A

#LMI operating code. Refer to LMI manual for operating instructions.

*This capacity is based on maximum obtainable boom angle.

NOTES:

1. All capacities above the bold line are based on structural strength of boom extension and do not exceed 85% of tipping loads, in accordance with SAE J765.
2. 36 ft. boom extension may be used for single or double line lifting service. 59 ft. boom extension may be used for single line lifting service only.

WARNING: Lifting with the 36 ft. extension base, with the 23 ft. extension fly either erected or folded along side of extension base, is strictly prohibited.

3. Radii listed are for a fully extended boom with the boom extension erected. For main boom lengths less than fully extended, the rated loads are determined by boom angle. Use only the column which corresponds to the boom extension length and offset for which the machine is configured. For boom angles not shown, use the rating of the next lower boom angle.

WARNING: Operation of this machine with heavier loads than the capacities listed is strictly prohibited. Machine tipping with boom extension occurs rapidly and without advance warning.

4. Boom angle is the angle above or below horizontal of the longitudinal axis of the boom base section after lifting rated load.
5. Capacities listed are with outriggers properly extended and vertical jacks set only.

THIS CHART IS ONLY A GUIDE AND SHOULD NOT BE USED TO OPERATE THE CRANE. The individual crane's load chart, operating instructions and other instructional plates must be read and understood prior to operating the crane.

Working Range



42-160 ft.
(12.8-48.8 m)

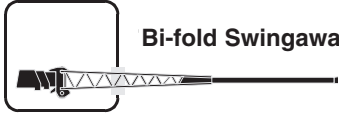

Bi-fold Swingaway

36-59 ft. (11-18 m)
+ 2 x 26 ft. (8 m) inserts

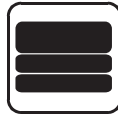

40,000 lbs.
(18 144 kg)



100%



360°

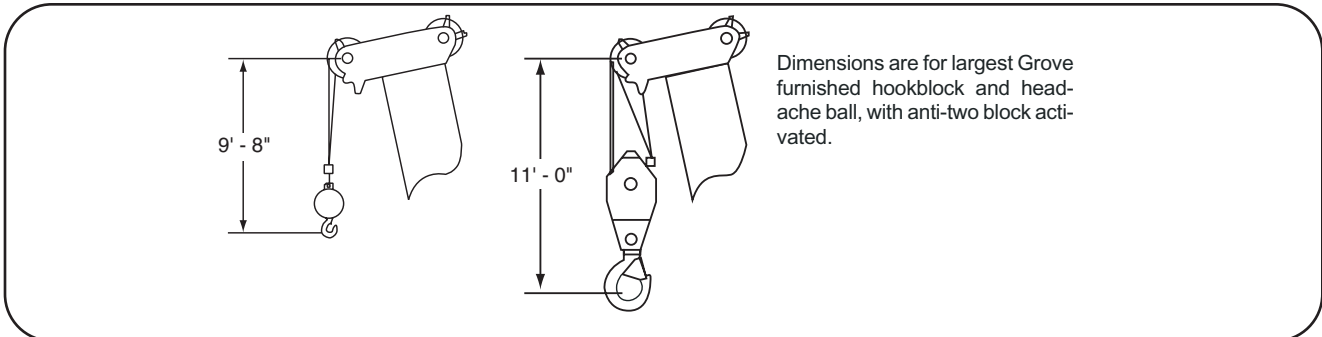
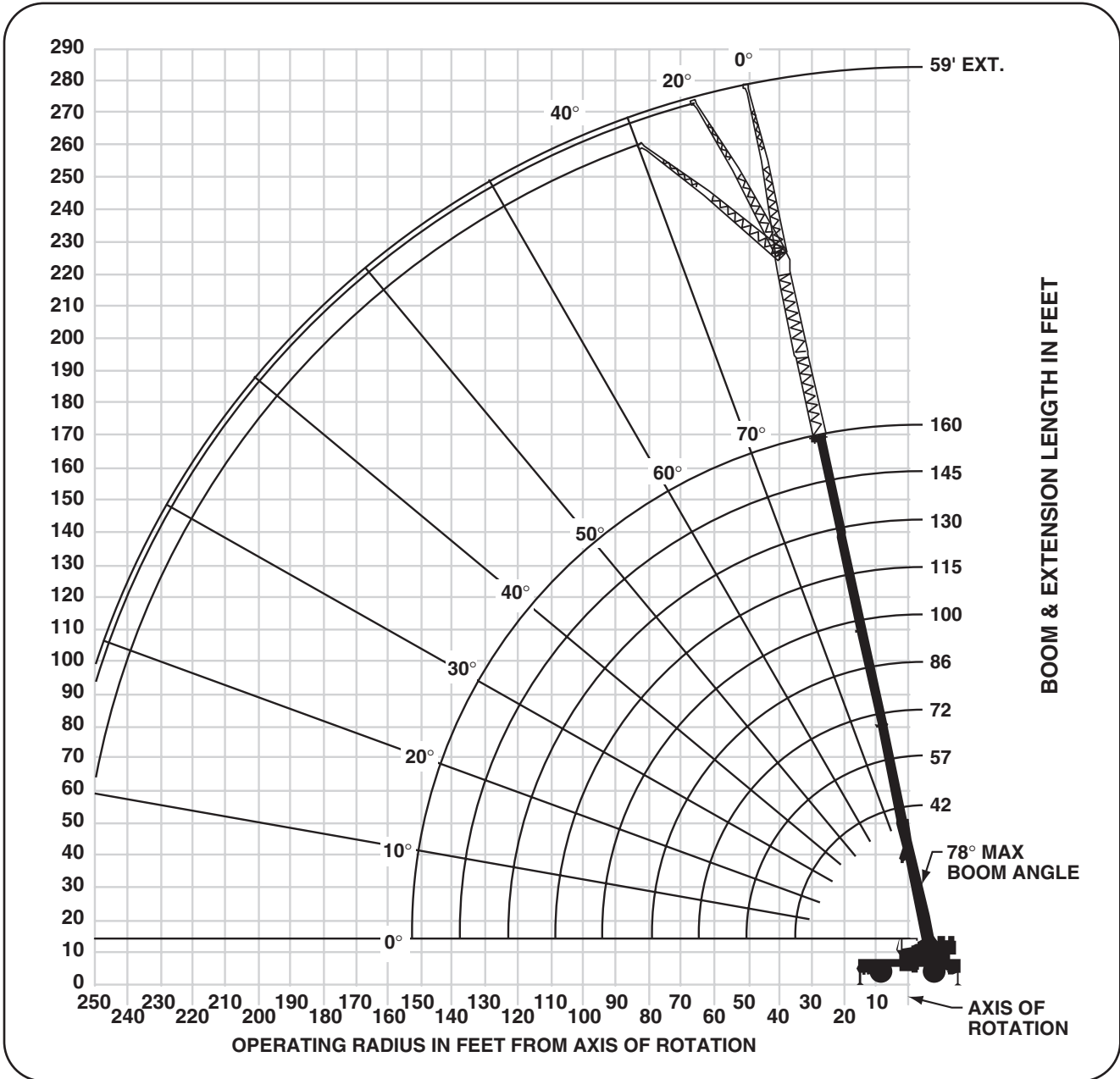

**59 FT. FOLDING BOOM EXTENSION WITH ONE (26') OR TWO (52') INSERT(S)
WITH 40,000 LB. COUNTERWEIGHT & 160 FT. MAIN BOOM
ON OUTRIGGERS FULLY EXTENDED - 360°**

Radius in Feet	59 ft. LENGTH WITH 26 ft. INSERT			59 ft. LENGTH WITH 52 ft. INSERT		
	0° OFFSET	20° OFFSET	40° OFFSET	0° OFFSET	20° OFFSET	40° OFFSET
	#0084	#0085	#0086	#0084	#0085	#0086
60	7,070 (78)					
65	7,070 (77.5)					
70	7,070 (76.5)			4,400 (78)		
75	7,070 (75)			4,400 (77.5)		
80	7,070 (74)	6,610 (78)		4,400 (76.5)		
85	7,070 (72.5)	6,610 (77.5)		4,400 (75.5)		
90	7,070 (71.5)	6,610 (76)		4,400 (74.5)	4,230 (78)	
95	7,070 (70)	6,610 (75)	6,400 (78)	4,400 (73)	4,230 (77.5)	
100	7,070 (69)	6,610 (73.5)	6,400 (77)	4,400 (72)	4,230 (76.5)	
105	7,070 (67.5)	6,610 (72.5)	6,400 (76)	4,400 (71)	4,230 (75.5)	4,000 (78)
110	7,070 (66)	6,610 (71)	6,400 (74.5)	4,400 (69.5)	4,230 (74)	4,000 (77)
115	6,735 (65)	6,545 (69.5)	6,315 (73)	4,400 (68.5)	4,230 (73)	4,000 (75.5)
120	6,400 (63.5)	6,480 (68)	6,230 (71.5)	4,400 (67.5)	4,230 (72)	4,000 (74.5)
125	5,940 (62)	6,170 (67)	5,955 (70)	4,400 (66)	4,230 (70.5)	4,000 (73)
130	5,480 (60.5)	5,860 (65.5)	5,680 (68.5)	4,400 (65)	4,230 (69.5)	4,000 (72)
135	4,930 (59.5)	5,510 (64)	5,440 (67)	4,110 (63.5)	4,195 (68)	4,000 (70.5)
140	4,380 (58)	5,160 (62.5)	5,200 (65.5)	3,820 (62.5)	4,160 (67)	4,000 (69)
145	3,900 (56.5)	4,645 (61)	4,910 (64)	3,350 (61)	3,885 (65.5)	3,785 (68)
150	3,420 (55)	4,130 (59.5)	4,620 (62.5)	2,880 (60)	3,610 (64)	3,570 (66.5)
155	3,000 (53.5)	3,680 (58)	4,140 (60.5)	2,470 (58.5)	3,205 (63)	3,365 (65)
160	2,580 (51.5)	3,230 (56.5)	3,660 (59)	2,060 (57)	2,800 (61.5)	3,160 (63.5)
165	2,210 (50)	2,825 (54.5)	3,220 (57.5)	1,690 (56)	2,405 (60)	2,810 (62.5)
170	1,840 (48.5)	2,420 (53)	2,780 (55.5)		2,010 (59)	2,460 (61)
175	1,515 (46.5)	2,060 (51)	2,385 (53.5)		1,655 (57.5)	2,075 (59.5)
180		1,700 (49.5)	1,990 (51.5)			1,690 (58)
185		1,370 (47.5)	1,625 (49.5)			
Min. boom angle (°) for indicated length (no load)	45	46	48	54	56	56
Max. boom length (ft.) at 0° boom angle (no load)	57			57		

NOTE: () Boom angles are in degrees.

A6-829-101983A

#LMI operating code. Refer to LMI manual for operating instructions.

1. All capacities above the bold line are based on structural strength of boom extension and do not exceed 85% of tipping loads, in accordance with SAE J-765.
2. 59 ft. folding boom extension length may be used for single line lifting service only.
NOTE: Lifting with 36 ft. extension base with either one or two 26 ft. insert sections installed is not permitted.
3. For main boom lengths less than 160 ft. with the boom extension erected, the rated loads are determined by boom angle. Use only the column which corresponds to the boom extension length and offset for which the machine is set up. For boom angles not shown, use rating of the next lower boom angle.
4. **WARNING:** Operation of this machine with heavier loads than the capacities listed is strictly prohibited. Machine tipping with boom extension occurs rapidly and without advance warning.
5. Boom angle is the angle above or below horizontal of the longitudinal axis of the boom base section after lifting rated load.
6. Capacities listed are with outriggers properly extended and vertical jacks set only.

THIS CHART IS ONLY A GUIDE AND SHOULD NOT BE USED TO OPERATE THE CRANE. The individual crane's load chart, operating instructions and other instructional plates must be read and understood prior to operating the crane.

ON RUBBER CAPACITIES WITH 40,000 LB. COUNTERWEIGHT

**PICK & CARRY CAPACITY
BOOM CENTERED OVER FRONT
UP TO 2.5 MPH (See note 7)**

Radius in Feet	#9006(40kcwt)			
	Main Boom Length in Feet			
	42	57	72	86
10	61,750 (71.5)			
12	61,750 (68.5)			
15	49,000 (63.5)	34,600 (71.5)		
20	34,750 (55.5)	34,600 (65.5)		
25	34,750 (46)	34,600 (60)		
30	29,250 (34)	28,150 (53.5)	28,300 (62.5)	
35	23,400 (13)	22,350 (46.5)	22,500 (58)	24,100 (64.5)
40		17,750 (38.5)	17,800 (52.5)	19,250 (60.5)
45		14,000 (28)	13,950 (47)	15,200 (56.5)
50		10,950 (7.5)	10,800 (41)	11,850 (52.5)
55			8,150 (34)	9,020 (47.5)
60			5,880 (24.5)	6,600 (42.5)
65				4,520 (37)
70				2,700 (30.5)
75				1,110 (22)
Min. boom angle (deg.) for indicated length (no load)			0	20
Max. boom length (ft.) at 0° boom angle (no load)			72	

#LMI operating code. Refer to LMI manual for instructions.

Note: () Boom angles are in degrees.

Lifting Capacities at Zero Degree Boom Angle				
Boom Angle	Main Boom Length in Feet			
	42	57		
0°	23,000 (35.3)	10,900 (50)		

Note: () Reference radii in feet. A6-829-102108A

1. Capacities are in pounds and do not exceed 75% of tipping loads as determined by test in accordance with SAE J765.
2. Capacities are applicable to machines equipped with 33.25x29 (38 ply) bias ply tires, at 85 psi cold inflation pressure.
3. Capacities appearing above the bold line are based on structural strength and tipping should not be relied upon as a capacity limitation.
4. Capacities are applicable only with machine on firm level surface.
5. On rubber lifting with boom extension not permitted.
6. Axle lockouts must be functioning when lifting on rubber.
7. For pick and carry operation, boom must be centered over front of machine, mechanical swing lock engaged and load restrained from swinging. When handling loads in the structural range with capacities close to maximum ratings, travel should be reduced to creep speeds.
8. All lifting depends on proper tire inflation, capacity and condition. Capacities must be reduced for lower tire inflation pressures. See lifting capacity chart for tire used. Damaged tires are hazardous to safe operation of crane.
9. Creep - not over 200 ft. of movement in any 30 minute period and not exceeding 1 mph.

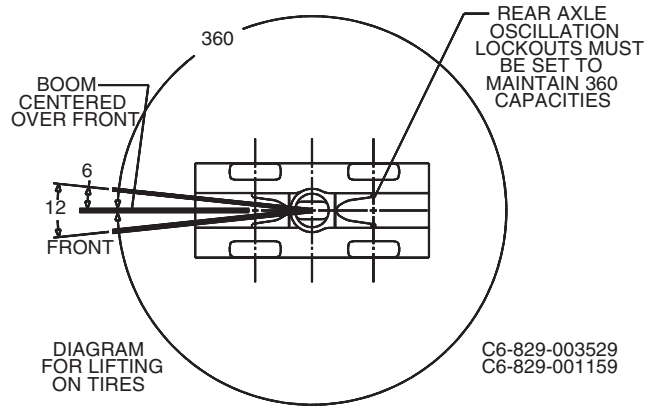
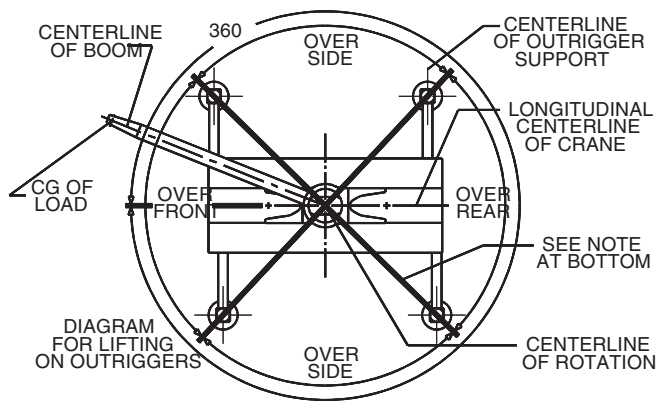

BOLD LINES DETERMINE THE LIMITING POSITION OF ANY LOAD FOR OPERATION WITHIN WORKING AREAS INDICATED

WEIGHT REDUCTIONS FOR LOAD HANDLING DEVICES

36 FT. - 59 FT. FOLDING BOOM EXTENSION	
*36 ft. Extension (Erected) -	5,260 lb.
*59 ft. Extension (Erected) -	9,860 lb.
FOLDING EXT. WITH 26 FT. INSERT	
*59 ft. Extension (Erected) -	14,100 lb.
FOLDING EXT. WITH 52 FT. INSERT	
*59 ft. Extension (Erected) -	19,400 lb.

*Reduction of main boom capacities

(no deduct required for stowed boom extension)

When lifting over main boom nose with 36 ft. or 59 ft. extension erected, the outriggers must be fully extended or 50% extended (19' 9" spread).

When lifting over main boom nose with 26 ft. or 52 ft. insert erected, the outriggers must be fully extended.

AUXILIARY BOOM NOSE	120 lb.
HOOKBLOCKS and HEADACHE BALLS:	
80 Ton, 5 Sheave	1,600 lb.+
130 Ton, 8 Sheave	2,400 lb.+
10 Ton Overhaul Ball	680 lb.+

+Refer to rating plate for actual weight.

When lifting over swingaway and/or jib combinations, deduct total weight of all load handling devices reeved over main boom nose directly from swingaway or jib capacity.

NOTE: All load handling devices and boom attachments are considered part of the load and suitable allowances MUST BE MADE for their combined weights. Weights are for Grove furnished equipment.

LINE PULLS AND REEVING INFORMATION

HOISTS	CABLE SPECS.	PERMISSIBLE LINE PULLS	NOMINAL CABLE LENGTH
Main Model 35	3/4" (19 mm) 18x19 Class Rotation Resistant Min. Breaking Str. 64,600 lb.	12,920 lb.	950 ft.
Main Model 35	3/4" (19 mm) 6x37 Class EIPS IWRC Special Flexible Min. Breaking Str. 58,800 lb.	16,800 lb.	950 ft.
Auxiliary Model 35	3/4" (19 mm) 18x19 Class Rotation Resistant Min. Breaking Str. 64,600 lb.	12,920 lb.	700 ft.

BOOM LENGTHS vs. SECTION EXTENSION PERCENTAGES

	Main Boom Length in Feet									
	42	57	72	86	100	115	130	145	160	
Boom sections:	Percent Extension									
Inner-mid	0	50	75	75	100	100	100	100	100	
Center-mid	0	0	25	75	100	100	100	100	100	
Outer-mid	0	0	0	0	0	25	50	75	100	
Fly	0	0	0	0	0	25	50	75	100	

THIS CHART IS ONLY A GUIDE AND SHOULD NOT BE USED TO OPERATE THE CRANE. The individual crane's load chart, operating instructions and other instructional plates must be read and understood prior to operating the crane.

RT9130E Features and Benefits



▶ Removable front and rear outrigger boxes provide up to 19,374 lbs. (8 788 kg) of weight reduction for easier transport. Include the removable 40,000 lbs. (18 100 kg) of counterweight, auxiliary hoist and rope, and the RT9130E can easily self-remove close to 64,000 lbs. (29 000 kg).

▶ In addition to the 130 ton capacity, the RT9130E is different from any other rough terrain crane in the industry because of its enormous reach.

A 59 ft. (18 m) offsettable bi-fold lattice swingaway extension and two-26 ft. (8 m) inserts give the RT9130E a maximum tip height of 279 ft. (85 m). A hydraulically offsettable bi-fold lattice swingaway is also available, and conveniently offsets from 0° to 40° from the operator's cab.

Only on all terrain cranes could this kind of main boom and extension height be achieved...until now.



▶ The 160 ft. (48.8 m) 5 section Full Power boom incorporates the "U" shaped MEGAFORM™ design, which eliminates stiffeners, thus reducing weight and increasing capacity.



▶ The "E" Series cab on the RT9130E tilts up to 20° providing the operator additional comfort when working at long boom and extension lengths.

Constant improvement and engineering progress make it necessary that we reserve the right to make specification, equipment, and price changes without notice. Illustrations shown may include optional equipment and accessories and may not include all standard equipment.

GROVE® and GROVE LOGO are registered trademarks of GROVE in the U.S. and/or other countries. Copyright© 2002 GROVE. All rights reserved.

Grove Worldwide - World Headquarters

1565 Buchanan Trail East

P.O. Box 21

Shady Grove, Pennsylvania 17256-0021, U.S.A.

Tel: (717) 597-8121

Fax: (717) 597-4062

www.groveworldwide.com



PACIFIC LIFT EQUIPMENT

The Crane Specialists

Rental / Sales

Phone: 866-708-5001

Fax: 360-424-8566

Parts / Service

Phone: 866-508-2001

Fax: 253-572-2915



LIEBHERR